



Horizontal Grinders for 3/8-24 Cone Wheels

400GH Series



400GHSK1;18000



400GHSR1;18000

507H Series



507HKS1;18000

Rated Speed	Exhaust Direction	Lever Style	MODEL NUMBER
20000 RPM	Side	Standard Lever	400GHS1;20000
		Safety Lever	400GHSK1;20000
	Rear	Standard Lever	400GHSR1;20000
		Safety Lever	400GHSKR1;20000
18000 RPM	Side	Standard Lever	400GHS1;18000
		Safety Lever	400GHSK1;18000
	Rear	Standard Lever	400GHSR1;18000
		Safety Lever	400GHSKR1;18000

Rated Speed	Exhaust Direction	Lever Style	MODEL NUMBER
18000 RPM	Side	Standard Lever	507HLS1;18000
		Safety Lever	507HKS1;18000

HORIZONTAL GRINDERS

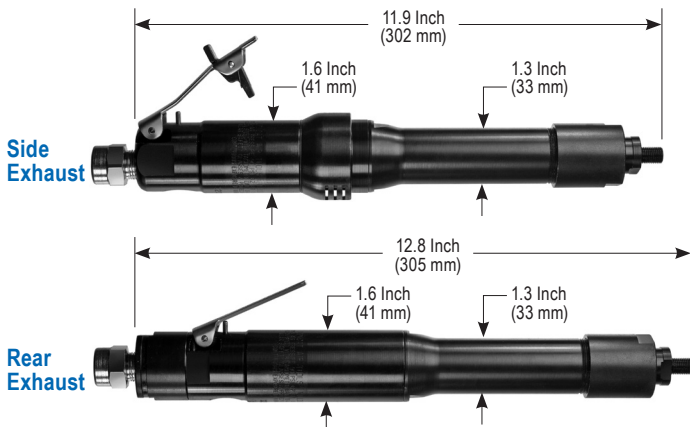

1.2 H.P.
(900 W)



35 cfm (16.5 L/s)



3.2 Lbs. (1.4 Kg) Aluminum
3.8 Lbs. (1.7 Kg) Steel



3/8" NPT Inlet
1/2" (13 mm) Hose Size

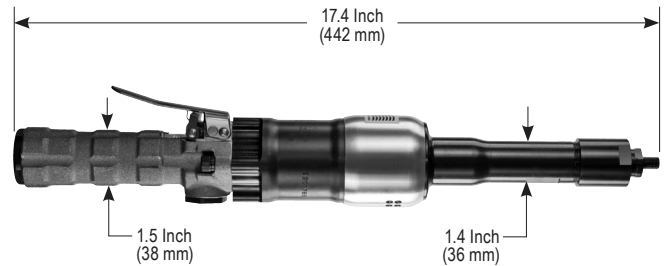

1.5 H.P.
(1.1 kW)



20 cfm (9.4 L/s) Free Speed
35 cfm (16.5 L/s) Max.



6.5 Lbs. (3.0 Kg) Steel Only



1/2" NPT Inlet
1/2" (13 mm) Hose Size

STANDARD EQUIPMENT

- Tool
- Operating Instructions and Service Manual
- Wrenches (sizes based on options)

400GH Series Series Alternate Options



Cone Wheel Mounting

